



# BRONZE SHUT OFF GATE VALVE (SOV)



## INSTALLATION DRAWINGS v1.2

**A + T INSTRUMENTS LTD**

235 BENTLEY WAY,

LYMINGTON,

HAMPSHIRE SO41 8JW

**UK**

TELEPHONE +44 (0)1590 718182

[INFO@AANDTINSTRUMENTS.COM](mailto:INFO@AANDTINSTRUMENTS.COM)

[WWW.AANDTINSTRUMENTS.COM](http://WWW.AANDTINSTRUMENTS.COM)

4 HOLES Ø 10.31 (0.406)  
ON 87.0 PCD  
(SEE NOTE BELOW REF  
ISOLATING KIT)

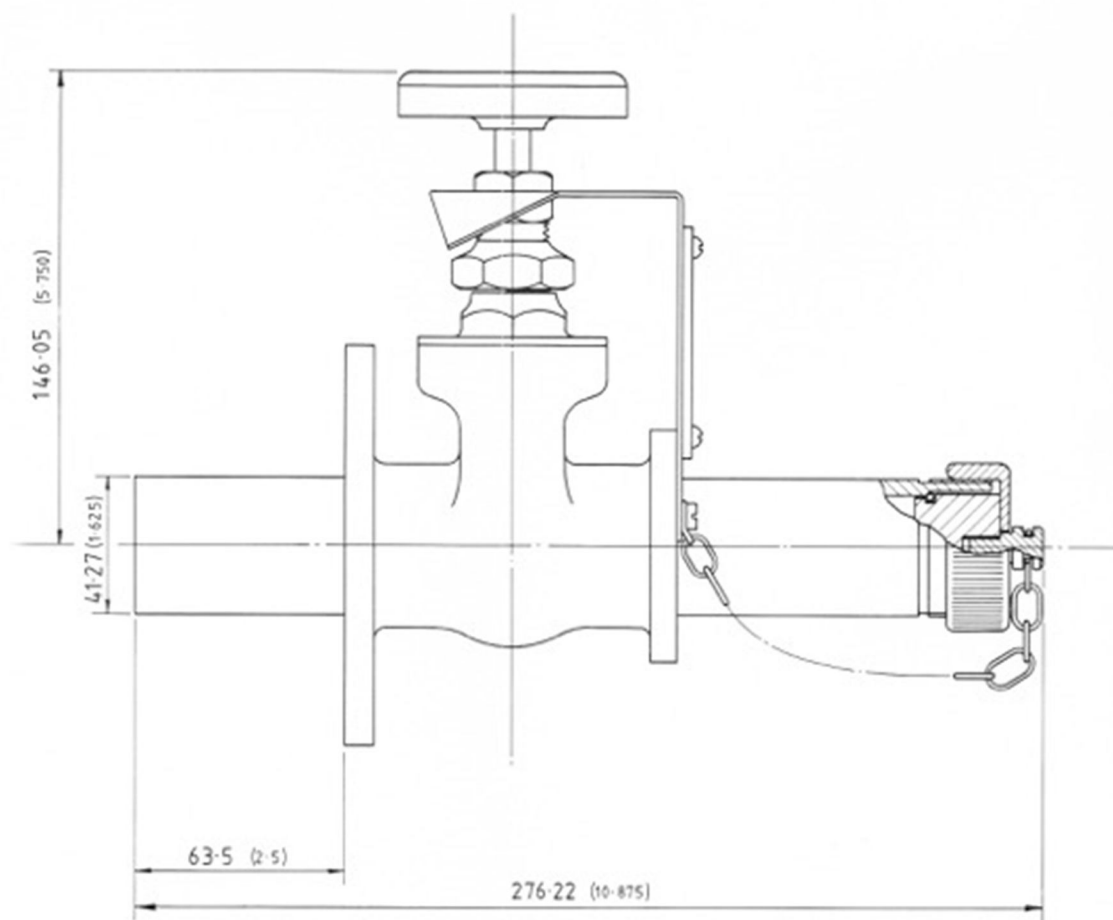
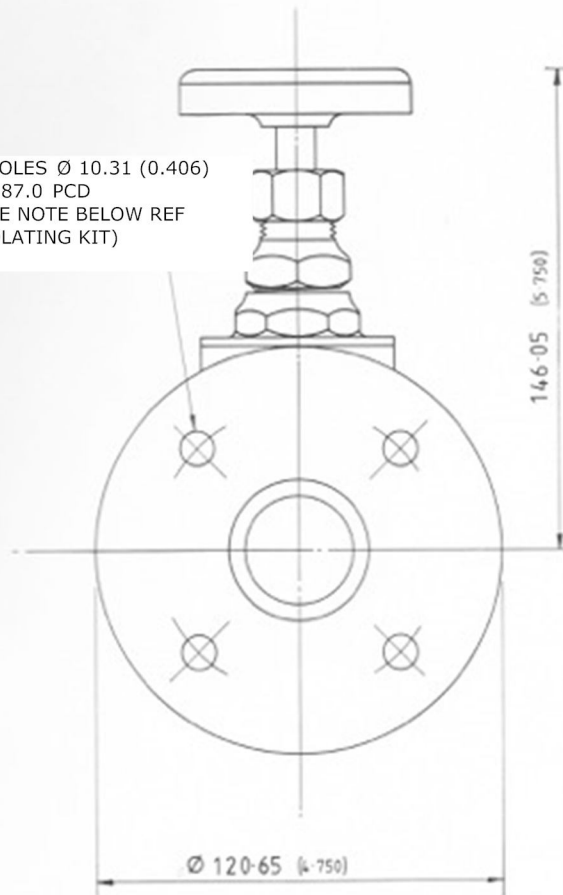

**Note**

1. Hole diameter above (10.31mm) if for direct mounting to GRP hull using M10 bolts
2. When used on conducting hulls with isolating kit then hole diameter is 14.25mm to take isolating bushes



**SOV Valve Mounting  
Mounting hole detail and GA**

DRAWN BY

HJA

DIMENSIONS

mm  
(Inches)

DATE

19/05/2017

SCALE

n/a

SHEET NO.

ATSOV 1  
V1.1

**NOTES**

1. STIFFEN HULL WITH EITHER WEBS OR INNER THICKENING PLATE
2. FLANGED BOSS 'A' TO BE WELDED/BONDED TO HULL AND FAIRED
3. USE SEALING COMPOUND BETWEEN TUFNOL PART AND FLANGE AND USE LOCKING ADHESIVE ON SCREW THREADS
4. CONSIDERATION SHOULD BE GIVEN TO PROTECTION AGAINST ELECTROLYSIS
5. SEE DRAWING ATSOV 3 FOR DETAILS OF OTHER PARTS B-E

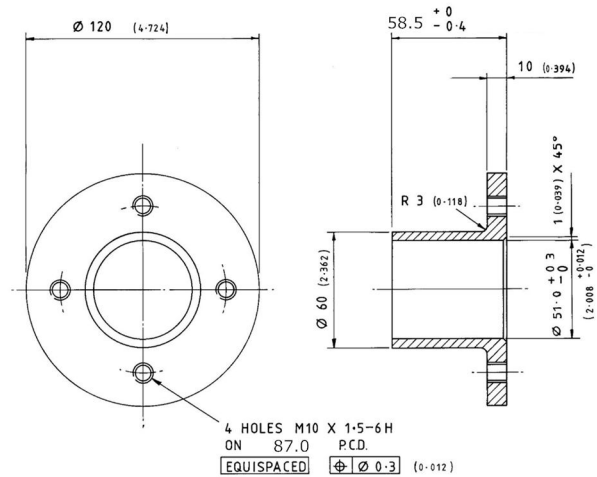

'A' FLANGED BOSS  
MATERIAL TO MATCH HULL

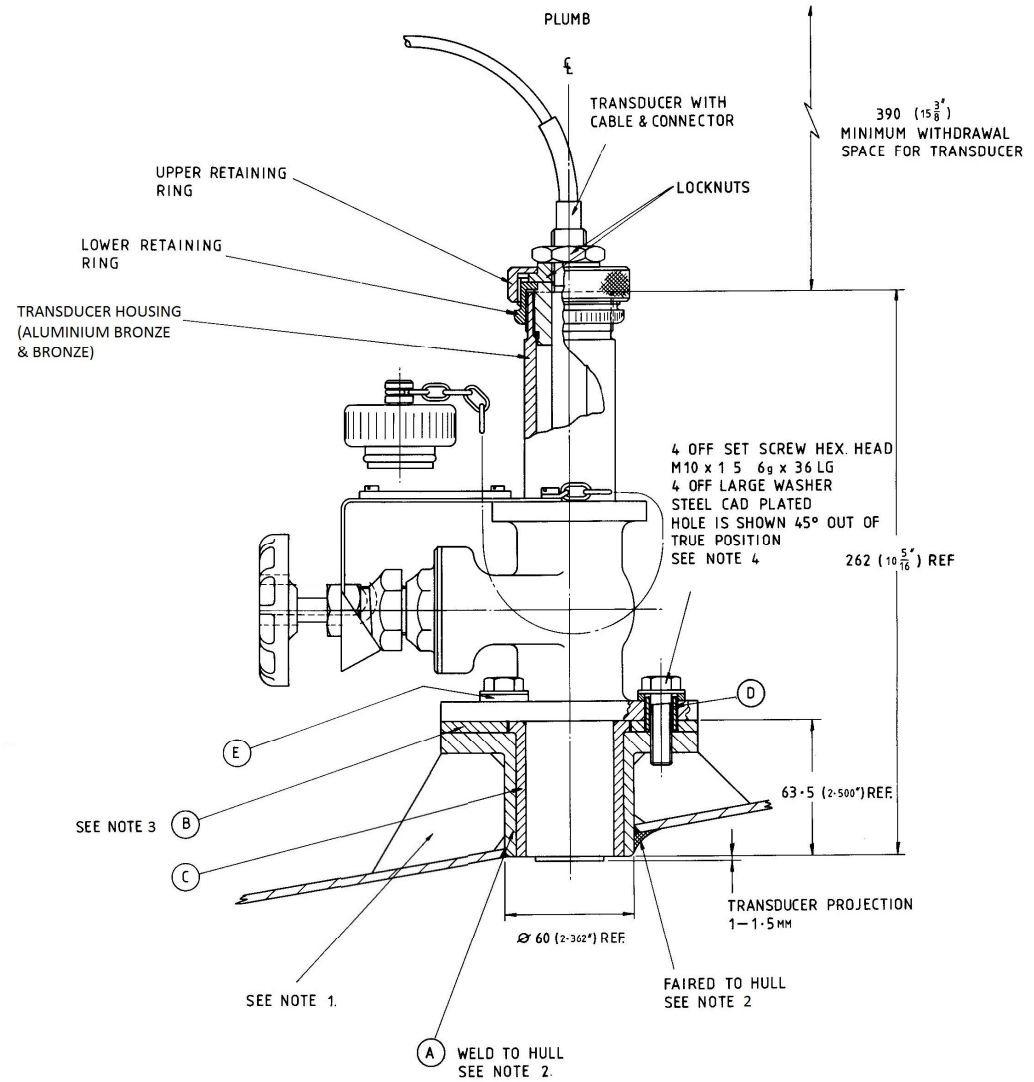

**SOV Valve Mounting**  
*Example installation Steel/  
Aluminium/Carbon Hulls*

DRAWN BY	DIMENSIONS	DATE	SCALE	SHEET NO.
HJA	mm (Inches)	19/05/2017	n/a	ATSOV 2 V1.1

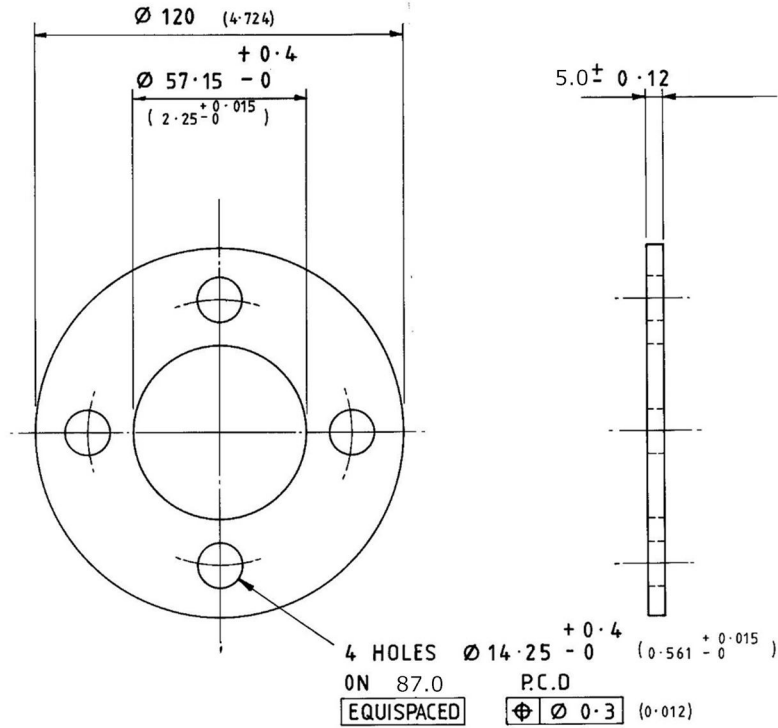

ITEM B WASHER

**NOTES**

1. MATERIAL TUFNOL CARP
2. TOLERANCE +/- 0.4 (0.015) UNLESS OTHERWISE STATED

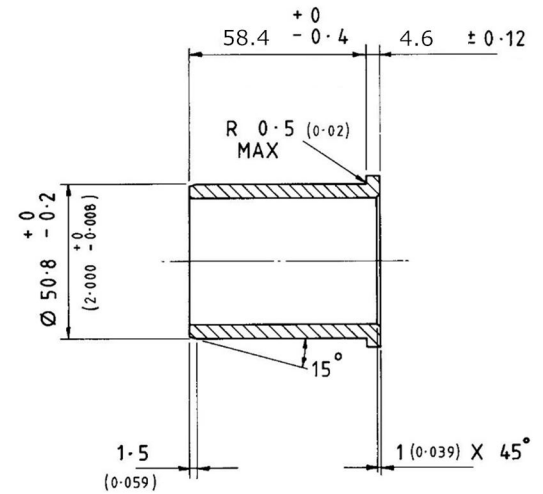
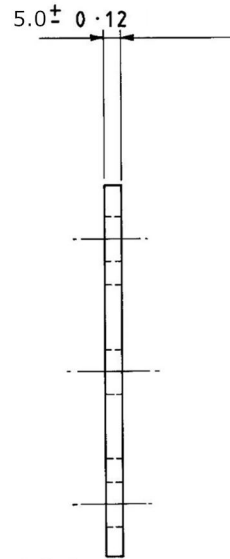

ITEM C BUSH

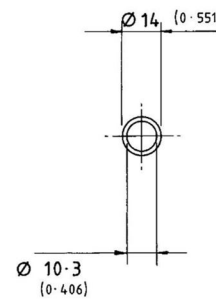

ITEM D BUSH

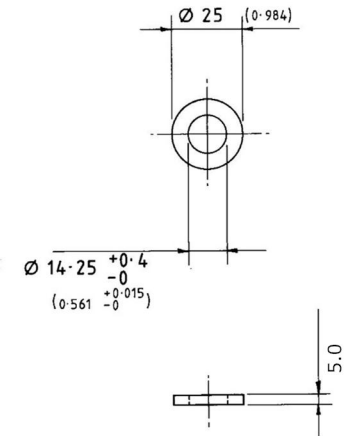

ITEM E WASHER



**SOV Valve Mounting  
Isolation Kit for Steel/  
Aluminium/Carbon Hulls**

DRAWN BY

HJA

DIMENSIONS

mm  
(Inches)

DATE

19/05/2017

SCALE

n/a

SHEET NO.

ATSOV 3  
V1.1

**NOTES**

1. USE SEALING COMPOUND BETWEEN GRP AND HOUSING FLANGE AND THREAD LOCKING ADHESIVE ON SCREW THREADS
2. KEEP BLANKING CAP IN STRONG POLYTHENE BAG WHEN SENSOR FITTED
3. CONSIDERATION SHOULD BE GIVEN TO PROTECTION AGAINST ELECTROLYSIS

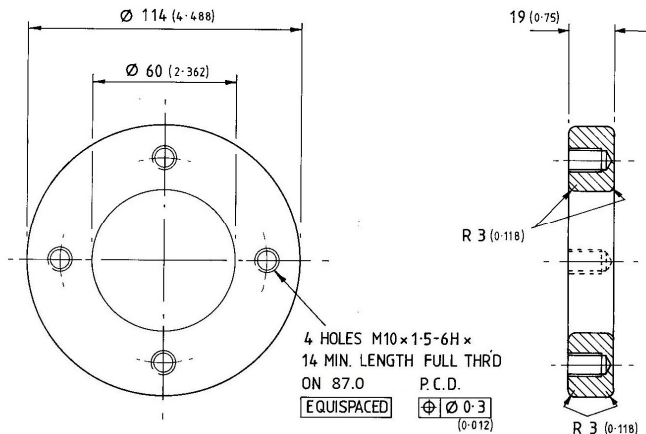

**'J' MOUNTING RING**

MATERIAL ALUMINIUM BRONZE

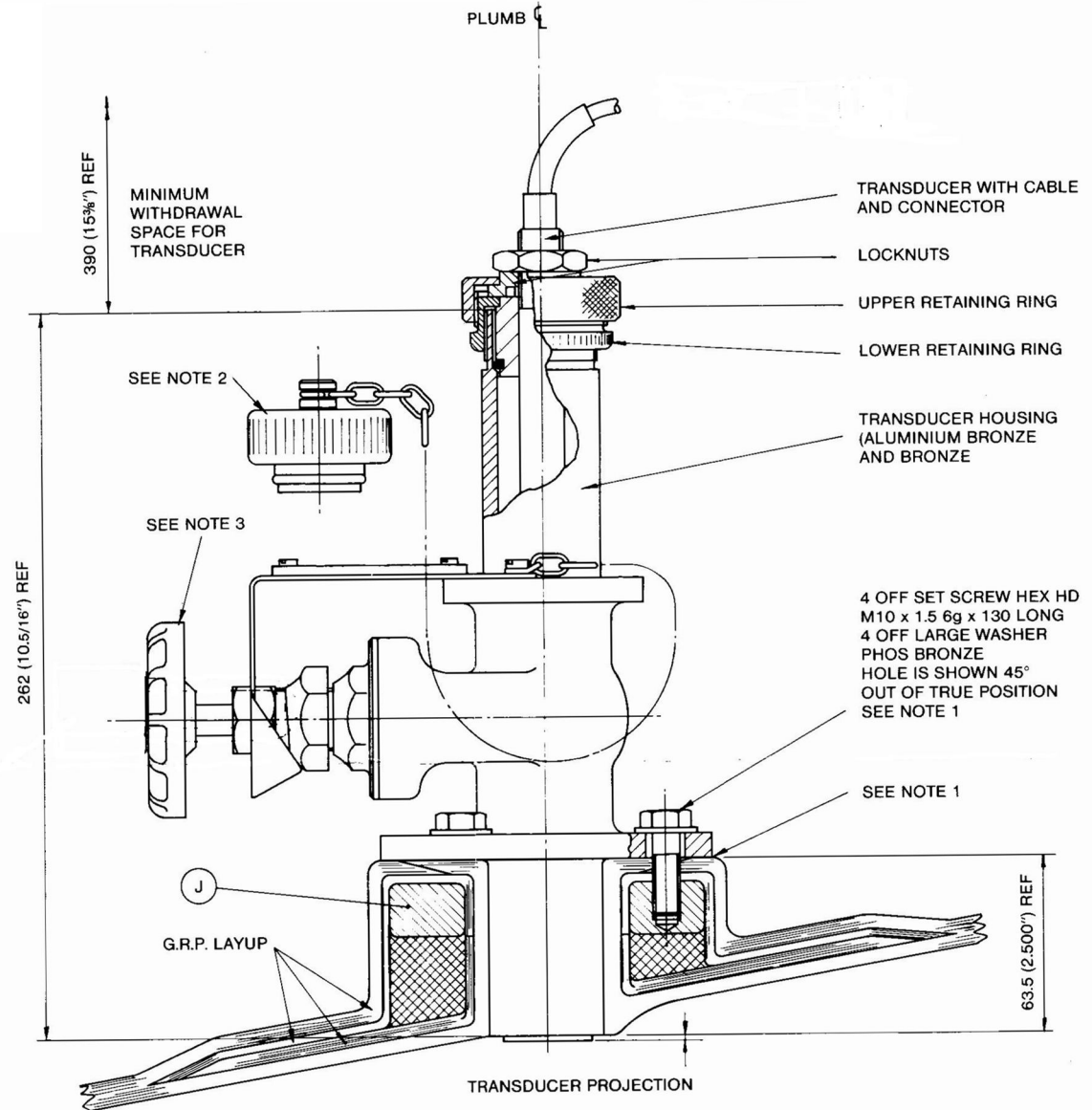

**SOV Valve Mounting  
 Example installation  
 GRP Hull**

DRAWN BY

DIMENSIONS

DATE

SCALE

SHEET NO.

HJA

mm  
(Inches)

19/05/2017

n/a

ATSOV 4  
 V1.1